



AUTOMATIC OUTDOOR ICE MAKER

Model # 5597A

INSTALLATION INSTRUCTIONS AND OWNER'S MANUAL

INSTALLER: Leave these instructions with consumer.
CONSUMER: Retain for future reference.



Important: READ THESE INSTRUCTIONS CAREFULLY BEFORE STARTING INSTALLATION OR USE.
KEEP THIS MANUAL IN A SAFE PLACE AFTER READING IT.

WARNINGS

Do not use where the supply voltage is different from the unit's requirements.

This product is designed for indoor/outdoor use.

The appearance, design, color, and parts of the product are subject to change without notice.

The functions and specifications stated in this manual may be changed at anytime without prior notice.

The manual has WARNING and CAUTION marks. The information is important for the safe and efficient installation and operation of the ice maker. Two types of cases may be found during installation:

CAUTION: If the instructions are not observed, a situation that may result in minor injury and/or damage to the product may occur.

WARNING: If the instructions are not observed, serious injury or death may result.

Thank you for purchasing the 5597A Ice Maker (drain pump is optional). The product is a built-in and free-standing type of ice maker and is designed for noncommercial use. The product produces transparent ice of the highest quality.

Proper installation of the ice maker is of the utmost importance. The product should be installed by a qualified professional service technician.

Before installing the product, read this installation manual in full. The manual contains detailed instructions to be observed during installation. If you have any questions about installation, contact your dealer.

Important: When designing or manufacturing the ice maker, safety matters and functions are accorded the utmost importance. This ice maker is designed and certified according to the UL safety standard. The company does not bear any responsibility or liability for products that are modified, installed with parts not supplied or approved, or used incorrectly. R.H. Peterson reserves the right to change product specifications and design at any time without prior notice.



GETTING STARTED

WARNINGS 1

IMPORTANT INFORMATION 3

UNPACKING 3

VENTILATION 3

WATER SUPPLY 3

WATER QUALITY 3

MAINTENANCE AND CLEANING 3

INTERIOR OF UNIT 3

ELECTRICAL SAFETY INFORMATION 4

SPECIFICATIONS AND DIMENSIONS 4

PARTS LIST 7

ITEM CHECK LIST 8

INSTALLATION

INSTALLATION 9

INSTALL ICE MAKER 9

DOOR REVERSAL (if applicable) 10

USE, CARE, & SERVICE

OPERATION 11

INITIAL OPERATION 11

USING THE ICE MAKER 11

ICE 11

ICE CONTAINER 11

OPERATION TIME 11

ICE PRODUCTION 12

ICE REMOVAL CYCLE 12

HOW IT MAKES ICE 12

ROUTINE MAINTENANCE AND CLEANING 13

EXTERIOR 13

ICE CONTAINER 13

CONDENSER 13

ICE-PRODUCTION SYSTEM 14

LONG TERM STORAGE OR NON-OPERATION (WINTERIZING) 14

TROUBLESHOOTING 15

WARRANTY 16

IMPORTANT INFORMATION

UNPACKING

After removing the packing materials, check the appearance of the ice maker for possible defects or irregularity. If the product shows any irregularity in its appearance, contact the dealer to inquire about it.

All the packing materials (strings, box, styrofoam, and wood, etc.) should not be left within reach of children and should be disposed of responsibly.

For safety, the product should be installed and used with caution in accordance with this manual. Incorrect installation or careless use of the product may cause damage or injury to the environment, humans, animals, and/or materials and property. The manufacturer does not bear any responsibility for any damage or injury.

The ice maker should NOT be installed near heat generators such as heaters, stoves, dish washers, or grills.

VENTILATION

The ice maker draws air through the left part of the kick plate/grill using a fan and expels hot air through the right parts of the kick plate/grill. If any material is placed in front of the kick plate/grill, the flow of air flow will be disrupted, and can result in reduced performance and/or malfunction. The ice maker should be operated within a temperature range of 50° F to 100° F.

CAUTION: Do not cover the kick plate/grill parts.

Note: A decoration door may be installed at the front but the ventilation holes of the kick plate/grill should not be blocked.

WATER SUPPLY

The ice maker requires a continuous supply of potable water from 20-80psi.

WATER QUALITY

There is no such thing as “perfectly pure” water. All water contains some impurities. Rainwater absorbs impurities from the atmosphere or when it passes through soil. Some impurities consist of solid particles called suspended solids and are filtered through micro filters. Any remaining impurities cannot be filtered because they are chemically combined with water molecules. These impurities are called dissolved solids.

The mineral content of the ice produced by the product is reduced compared to the content in the water before conversion into ice. Water containing a low level of impurities is rapidly frozen. The reason for this is that the impurities elevate the temperature of water. Through such an action, most of the impurities condensed in the water-tank of the ice maker form a hard precipitation called scale.

If a large quantity of mineral scale accumulates, the lifespan of the ice maker may be reduced.

For best operation of the ice maker, impurities and minerals should be decomposed by washing with vinegar periodically. See the **SERVICING AND CLEANING** section for details.

In general, it is best to use filtered water. Filters may remove not only bad odor but also particulates. Neutral water is not recommended.

Water softener is not recommended because it exchanges minerals. If the hardness of the water is very high, softening may lead to the attachment of opaque pieces of ice.

If you have any questions about the purity of your water, contact your local water department.

MAINTENANCE AND CLEANING

Proper operation of the ice maker requires routine maintenance and cleaning, see the **ROUTINE MAINTENANCE AND CLEANING** section for details.

INTERIOR OF UNIT

This product was thoroughly washed at the factory. However, check the cleanness of the inside before use and keep it clean during use.

WARNING: Used refrigerators and freezers should be safely stored or disposed of. Ensure that the product's door has been removed or permanently closed. If children are able to enter the ice maker, a serious accident may occur.

ELECTRICAL SAFETY INFORMATION

- To protect against electric shock, do not immerse cord or plugs in water or other liquid.
- Unplug from the outlet when not in use and before cleaning.
- **CAUTION: Risk of Electric Shock - Switch in OFF position does not de-energize the unit.**
- Do not operate any outdoor appliance with a damaged cord, plug, or after the appliance malfunctions or has been damaged in any manner. Contact the manufacturer for repair.
- Do not let the cord touch hot surfaces.
- Do not use an outdoor appliance for purposes other than intended.
- **Use only a properly wired and inspected 120VAC (15 AMP minimum) Ground Fault Circuit Interrupter (GFCI) GROUNDED 3-wire receptacle with this outdoor appliance.**
- The GFCI receptacle must be a WEATHER-PROOF IN-USE COVERED RECEPTACLE.
- Never remove the grounding plug or use with an adapter of 2 prongs.
- Use only extension cords with a 3 prong grounding plug, rated for the power of the equipment, and approved for outdoor use with a W-A marking.
- **The provisions of the National Electric Code as well as any local codes must be observed when installing the product.**

SPECIFICATIONS AND DIMENSIONS

| Description | | Measurement | Specification |
|------------------------|-------|------------------|--|
| Rated power | | V / A / Hz | 120V / 4.0A Max / 60Hz |
| Power consumption | | W | MAX 500 |
| Overall dimension | | W x D x H (inch) | 15 x 25 1/4 x 34-35 |
| Weight | Net | lb | 103.6 |
| | Gross | lb | 119 |
| Exterior | | -- | Top, side, front: durable stainless steel |
| Quantity of ice | | EA | 24 cubes per cycle |
| Maximum product | | lb / day | 63.9 |
| Ice storage capacity | | lb | 26.5 |
| Refrigerant | | -- | R513a |
| Evaporator design | | -- | Spray type (cube) |
| Condenser | | -- | Air-cooled |
| Water supply condition | | °F (°C) | 50 ~ 86 (10 ~ 32) |
| Remark | | -- | Self-container type |

Table 1 - Product Specifications

SPECIFICATIONS AND DIMENSIONS (cont.)

When moving the ice maker, ensure the cut-out dimensions, electric power, and piping position requirements are met. Refer to the INSTALLATION section for complete details.

This product is a gravity drain model that requires a drain tube to run from the back of the product to an appropriate drain pipe. The optional drain pump routes water to a drainage point such as a neighboring sink.

Important: The ice maker should be leveled.

Important: When moving the product using a hand truck or dolly, place the dolly at the side of the product and shut or fix the door tightly to avoid possible opening during movement.

CAUTION: The finished bottom should be protected with a suitable material to avoid possible damage when moving the product.

| Cut-out dimensions | |
|--|---------|
| A Height (top to bottom) min. cut-out | 34" |
| B Width (side to side) cut-out | 15 1/4" |
| C Depth (front to back) min. cut-out | 25 1/4" |
| Unit dimensions | |
| D Width (door closed) | 15" |
| E Width (maximum, door fully open) | 25 1/2" |
| F Height | 33 3/4" |
| G Levelers maximum height | 1" |
| H Depth (maximum, door closed) | 25 1/4" |
| I Depth (body only) | 21 1/4" |
| J Depth (body and door w/o handle) | 22 3/4" |
| K Depth (door open 90°) | 36 3/4" |
| L Depth (door open maximum 105°) | 34 3/4" |

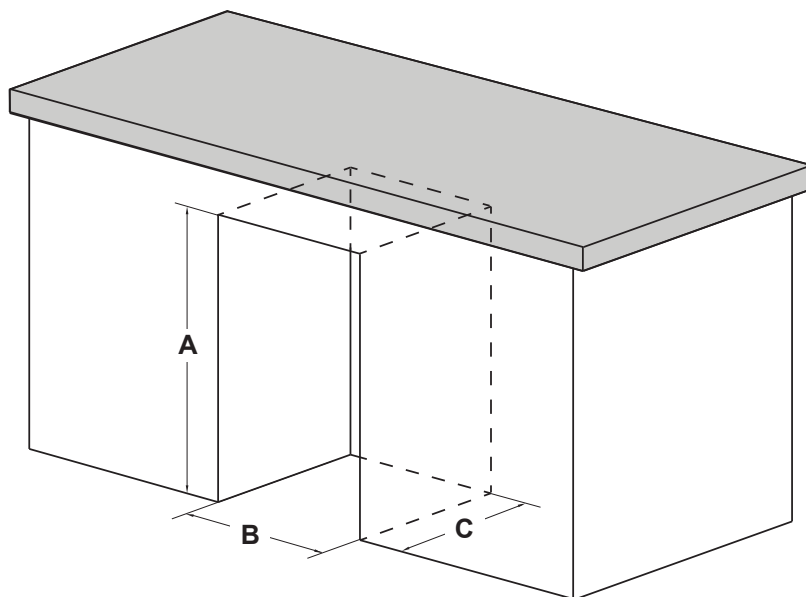

Fig. 5-1 Cut-out dimensions

Table 2 - Dimensions diagram

Note: If using a trim kit (purchased separately), cut-out dimensions remain the same.

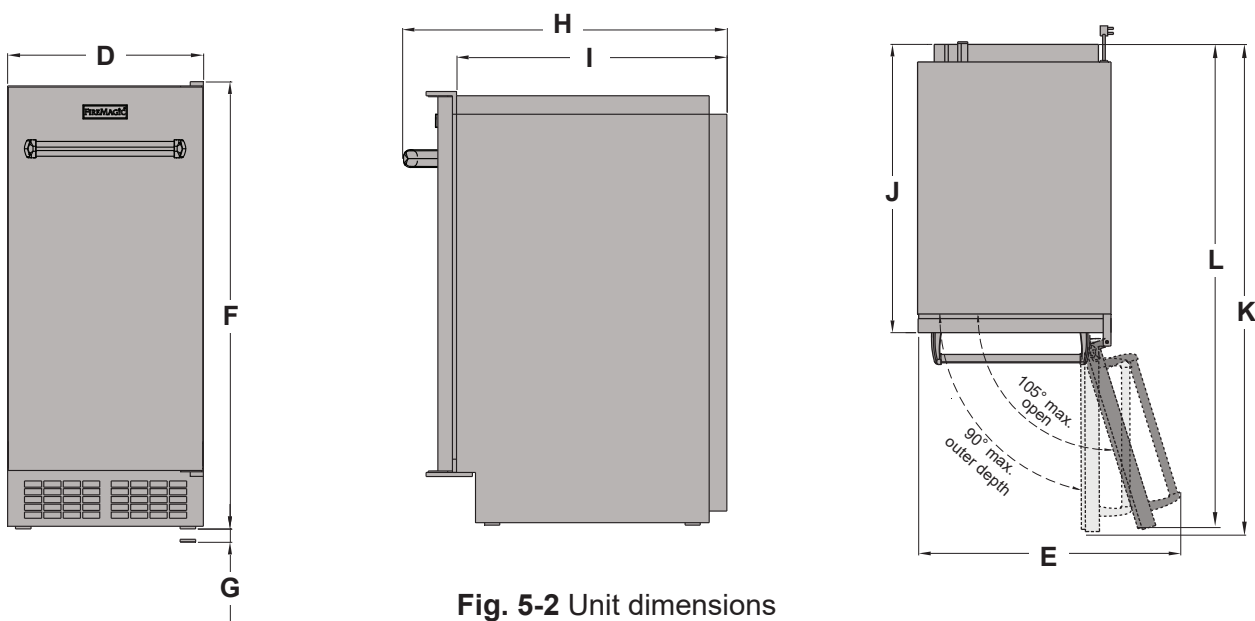

Fig. 5-2 Unit dimensions

SPECIFICATIONS AND DIMENSIONS (cont.)

PLUMBING REQUIREMENTS

Plan for the setup of the water supply pipes.

Connect the unit to a cold water source using the supplied water inlet hose.

Install a shut-off valve between the tap water pipe and the product so that the user can operate the valve. Do not install the shut-off valve at the rear of the product.

Do not use a self-piercing valve. If the tap water has a high level of minerals, a pipeline filter will be required.

The pressure of the tap water should be maintained at a level between 20psi and 80psi. An electric outlet installed behind the ice maker will make installation easier. Installation of the outlet, tap water pipe, and drain pipeline should meet all provisions under local laws and regulations. Refer to the INSTALLATION section for complete details.

Important: The unit must remain removable for servicing. Do not install any material at the front, upper or lower end of the product which may prevent removal of the unit.

Important: Piping should be setup in accordance with all the provisions of local laws and regulations.

PARTS LIST

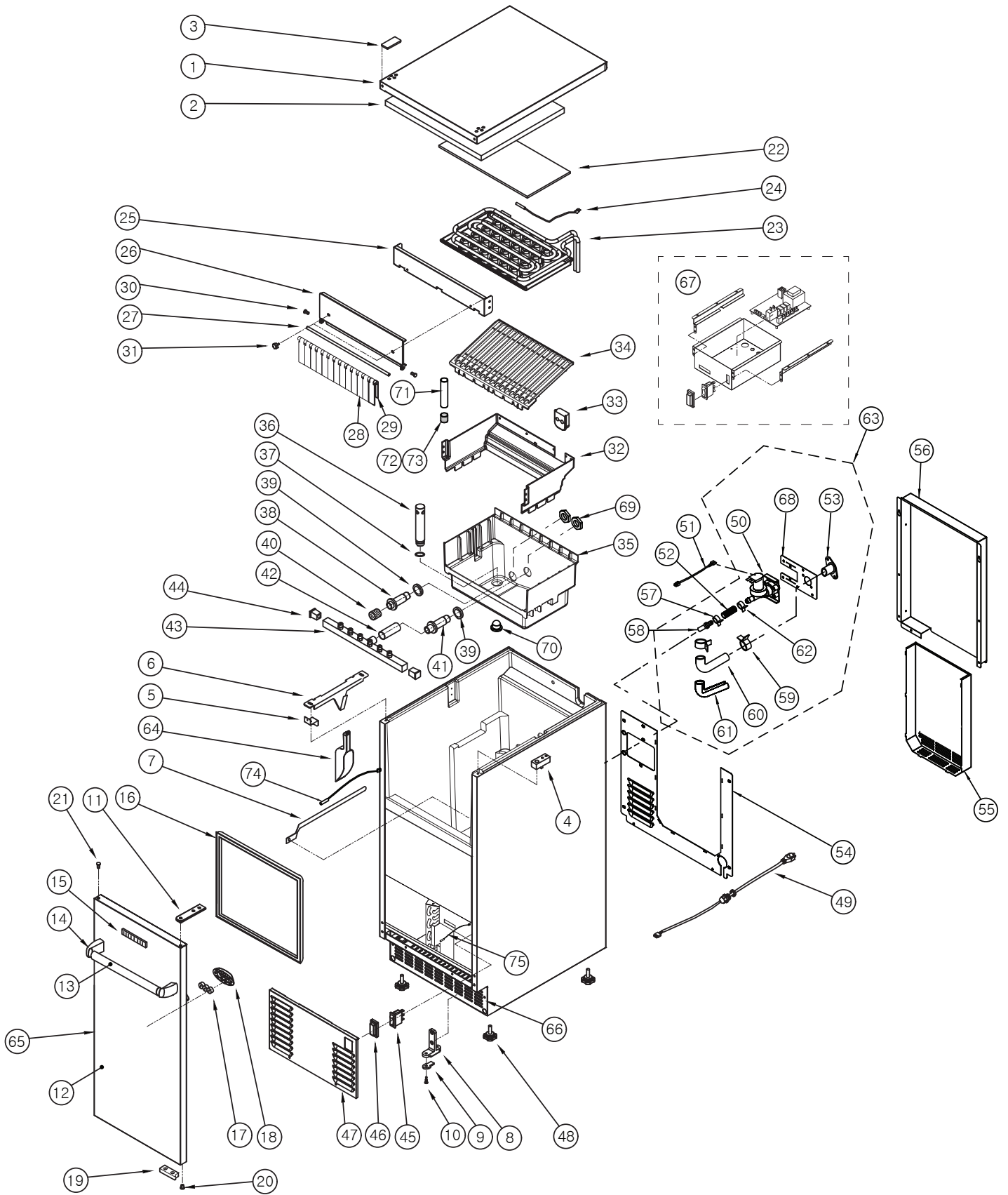

PARTS LIST (cont.)

| Item | Description | Code No. | Qty. | Replacement Part No. * | Item | Description | Code No. | Qty. | Replacement Part No. * |
|------|-----------------------------|------------|------|------------------------|------|--------------------------------|------------|------|------------------------|
| 1. | Top cover | 4430402-10 | 1 | - | 39. | Packing nipple | 3030055-01 | 2 | - |
| 2. | Foam top cover | 3060191-00 | 1 | - | 40. | Strainer | 6050011-01 | 1 | - |
| 3. | Hinge plug | 3030182-00 | 1 | - | 41. | Bolt/vessel IN/OUT | 2140155-00 | 1 | - |
| 4. | Top hinge block | 3210030-00 | 1 | - | 42. | Hose nipple | 2290114-00 | 1 | - |
| 5. | Top cover bracket | 3210025-10 | 1 | - | 43. | Nozzle frame | 3480081-00 | 1 | - |
| 6. | Reversible ice scoop hanger | 6820004-00 | 1 | - | 44. | Cover nozzle | 3030221-00 | 2 | - |
| 7. | Safety TC shaft | 3160040-10 | 1 | 5597A-14 | 45. | Rocker switch | 3550133-00 | 1 | 3597-12 |
| 8. | Door hinge - bottom | 3210027-00 | 1 | 3597-15 | 46. | Cover, rocker switch | 3550089-00 | 1 | 3597-17 |
| 9. | Door stop bracket | 3980092-00 | 1 | - | 47. | Front cover plate | 3170894-10 | 1 | - |
| 10. | Door stopper bolt | 2140170-00 | 1 | - | 48. | Leveling foot | 3020029-00 | 1 | - |
| 11. | Upper door hinge | 3210028-10 | 1 | 3597-16 | 49. | Power cord assy | 7220007-01 | 1 | - |
| 12. | Door - front panel | 4470118-00 | 1 | - | 50. | Water inlet valve | 3400287-00 | 1 | 5597A-18 |
| 13. | Handle bar | - | 1 | - | 51. | Harness water | 3770456-00 | 1 | - |
| 14. | Handle bar support | - | 2 | - | 52. | Braided silicone hose | 2290278-00 | 1 | - |
| 15. | Logo plate | - | 1 | - | 53. | Socket | 2150134-00 | 1 | - |
| 16. | Door gasket | 6560010-04 | 1 | 5597A-21 | 54. | Back down base | 3490546-20 | 1 | - |
| 17. | Door magnet | 3220039-00 | 3 | - | 55. | Back down cover | 3490629-10 | 1 | - |
| 18. | Cover magnet | 3170907-00 | 1 | - | 56. | Back cover | 3490598-10 | 1 | - |
| 19. | Door bottom bracket | 3980093-00 | 1 | - | 57. | Ban spring 15 | 2030038-00 | 1 | - |
| 20. | Door bearing | 3270075-01 | 1 | - | 58. | Tube-to-hose stem | 3980142-00 | 1 | - |
| 21. | Door top button | 3180194-00 | 1 | - | 59. | Band spring 23 | 2030022-00 | 1 | - |
| 22. | Cover EVA sheet | 3170909-00 | 1 | - | 60. | Hose pump out | 2290121-00 | 1 | - |
| 23. | EVA plating assy | 4090344-03 | 1 | - | 61. | Foam PE (pump out) | 3060162-00 | 1 | - |
| 24. | EVA sensor (N) | 6550072-00 | 1 | 3597-19 | 62. | Band spring 18 | 2030039-00 | 1 | - |
| 25. | Bracket EVA | 3010596-00 | 1 | - | 63. | Assy. water in/drain (no pump) | 4680201-00 | 1 | - |
| 26. | Bracket flow ice | 3010677-01 | 1 | - | 64. | Ice scoop | - | 1 | 3597-11 |
| 27. | Pin flow ice | 3150037-00 | 1 | - | 65. | Door assy w/ handle | 4470119-00 | 1 | 3597-10 |
| 28. | Flow ice front | 3170728-10 | 13 | - | 66. | Kick plate | 3171717-00 | 1 | 3597-13 |
| 29. | Flow ice back | 3170766-00 | 14 | - | 67. | Control box w/ PCB | 4260683-00 | 1 | 5597A-20 |
| 30. | Button support | 3180194-00 | 2 | - | 68. | Bracket water valve | 3011672-00 | 1 | - |
| 31. | Hand screw | 2108045-01 | 2 | - | 69. | Nut | 2150075-00 | 2 | - |
| 32. | Cover vessel | 3170906-00 | 1 | - | 70. | Plug | 3030220-00 | 1 | - |
| 33. | Rubber EVA pipe | 2110076-00 | 1 | - | 71. | Drain hose | 2290306-00 | 1 | - |
| 34. | Ice guide | 3410090-02 | 1 | - | 72. | Strainer upper | 6050014-01 | 1 | - |
| 35. | Vessel | 6040014-00 | 1 | - | 73. | Strainer lower | 6050015-01 | 1 | - |
| 36. | Over flow pipe | 3030174-00 | 1 | - | 74. | EVA sensor SB | 6550082-00 | 1 | - |
| 37. | Packing over flow | 3030166-00 | 1 | - | 75. | Air sensor (M) | 6550099-00 | 1 | - |
| 38. | Bolt vessel IN | 6100180-00 | 1 | - | | | | | |

* Items with replacement part numbers are available from your dealer. Other items require a special order from Fire Magic and may have extended lead times.

ITEM CHECK LIST

Prior to installation, check that all the following items have been included with your unit. If any items listed below are missing, contact your dealer.

- Ice maker
- Inlet hose
- Outlet hose
- Ice scoop

INSTALLATION

INSTALL ICE MAKER

This installation method is for a **gravity drain pipe setup**. If the optional drain pump kit is purchased, follow the installation instructions provided with the pump.

Refer to plumbing codes when connecting the ice maker to a drain connection.

Before connecting the drain tube and the water inlet hose to the ice maker, pipes [including shut-off valve and water filter (if needed)] should be properly setup. The drain tube should slope $\frac{1}{4}$ " for every foot. An air gap is required between the drainage tube of the ice maker and the drain pipe.

Important: Incorrect installation of the drainage pipe will cause the ice in the ice container to melt rapidly.

1. Locate the back of the ice maker at the front of the enclosure cut-out opening.
2. Connect the supplied water inlet hose to the ice maker using the supplied flare adapter (see Fig. 9-3).
3. Connect the other end of the water inlet hose to the water supply shut-off valve. (see Fig. 9-3).

Note: If a water filter (not included) is installed between the shut-off valve and the ice maker, connect the water inlet hose to the water filter, and the water filter to the shut-off valve. See Fig. 9-3.

4. Cut the required length of drain tube.
5. Connect the drain tube (with a diameter of $\frac{5}{8}$ ") to the drain pipe at the rear of the product and secure them together using a hose clamp. See Fig. 9-1 for orientation.
6. Turn on the shut-off valve and check for leaks.
7. Insert the plug into the electrical receptacle.
8. Slide ice maker into position. Do not kink water or drain lines.
9. Level the ice maker by adjusting the leveling legs: turn counterclockwise to raise the unit, or clockwise to lower it. See Fig. 9-2.

The user does not need to fill the container with water. The first batch of ice should be discarded. Ice production takes 1-2 hours.

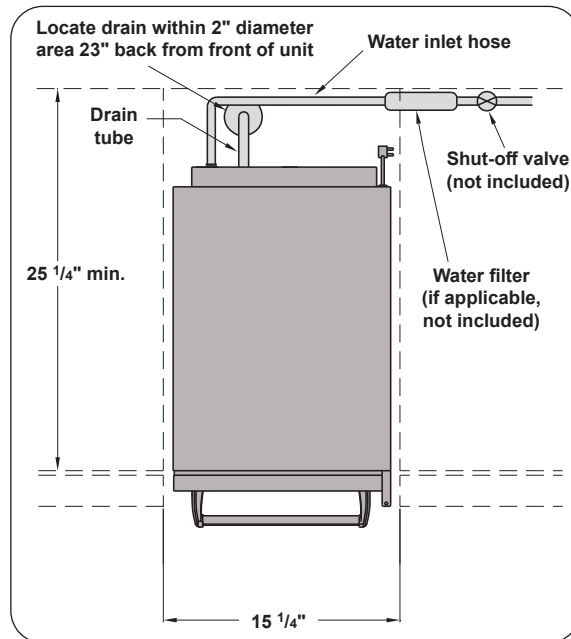

Fig. 9-1 Top view

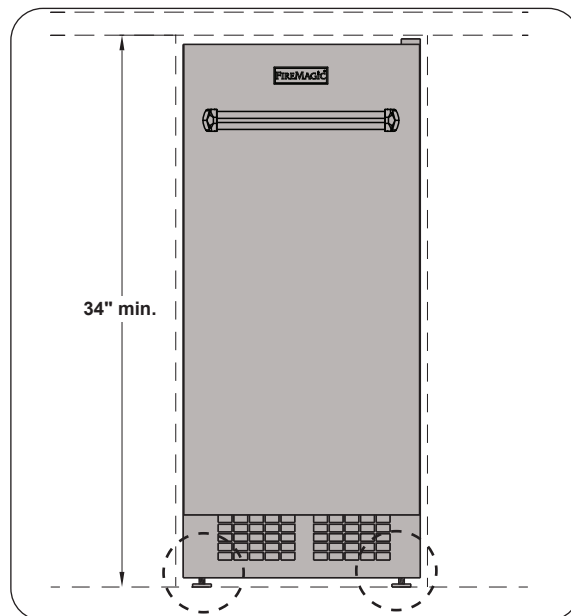

Fig. 9-2 Front view

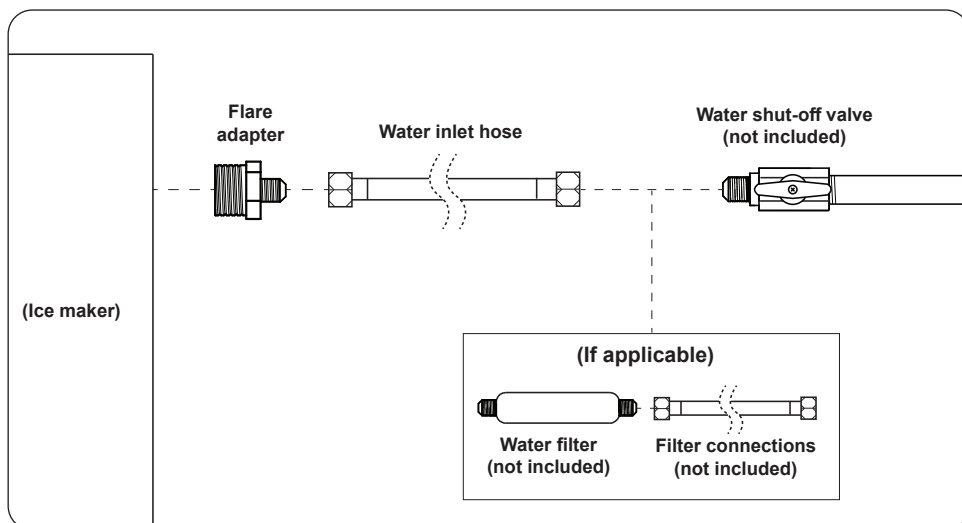
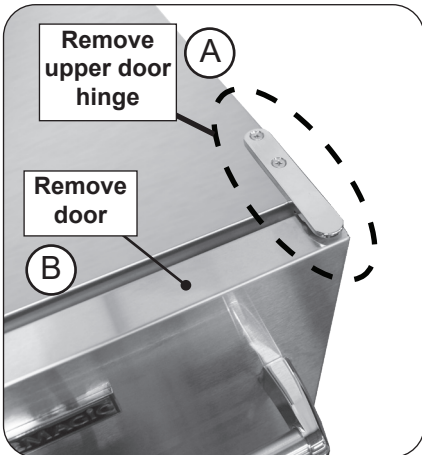

Fig. 9-3 Water connection diagram

INSTALLATION (cont.)

DOOR REVERSAL (if applicable)

The direction in which the door opens can be changed. The hinges are attached to the right-hand side of the door when the product is shipped from the factory. The ice maker is designed so that the hinges may be installed on either side. If the hinges are moved to the holes on the left-hand side, the door will open to the left.



1. Remove the upper door hinge, then carefully lift and remove the door.

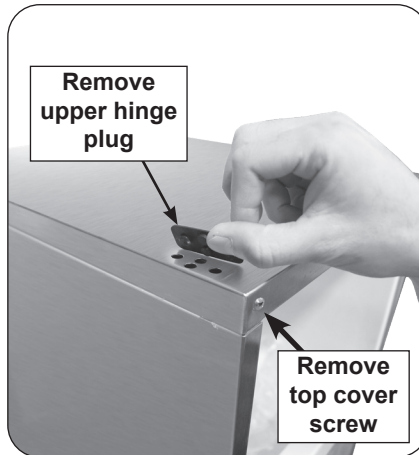

2. Remove the upper hinge plug and the top cover screw.

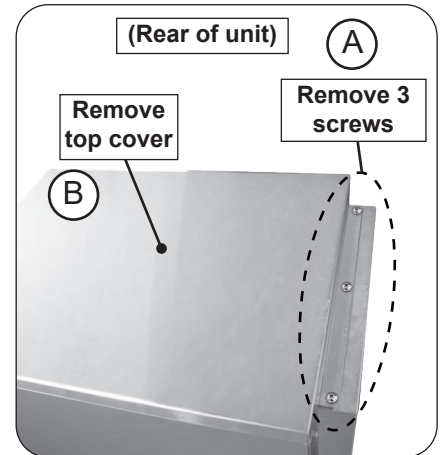

3. Remove the 3 top cover screws at the rear of the unit, then remove the top cover.

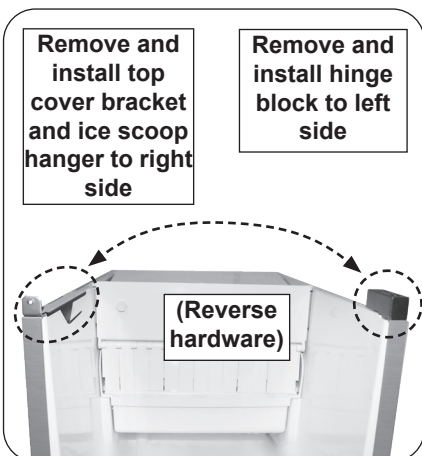

4. Remove and install the top cover bracket and ice scoop hanger to the right side and the hinge block to the left side.

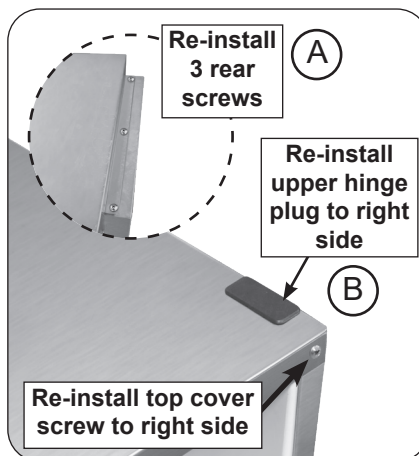

5. Re-install the top cover using the 3 rear screws and 1 front screw. Install the upper hinge plug to the right side.

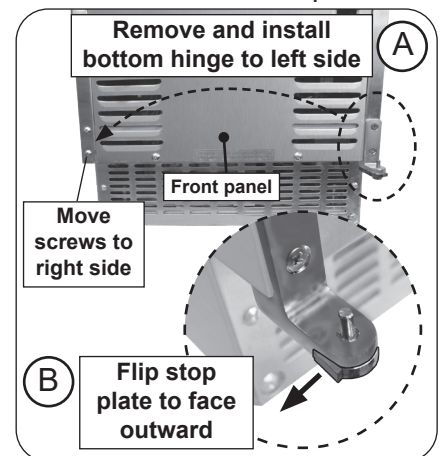

6. Remove and install bottom hinge to the left side. Remove bottom screw and flip the door stop plate as shown.

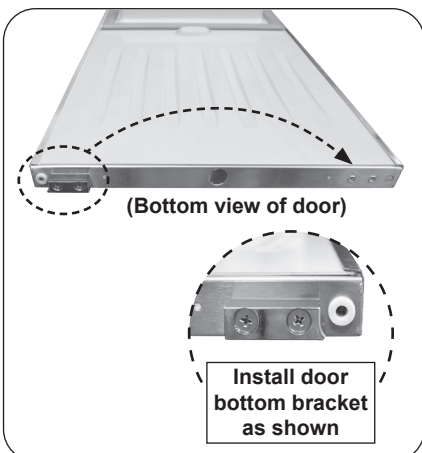

7. Remove and install the door bottom bracket and plastic insert to the right side of the door bottom.

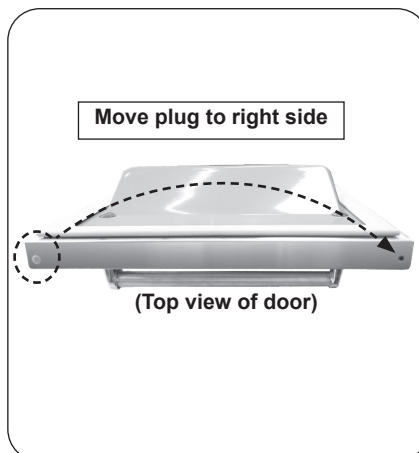

8. Remove and install the door top plug to the right side.



9. Re-install the door to the bottom hinge. While holding the door in place, install the top door hinge.

OPERATION

INITIAL OPERATION

1. Ensure the water supply shut-off valve connected to the ice maker is open.
2. Open the door and turn the switch at the lower end of the product to the "ICE" position.
3. Discard the first batch of ice.
4. Good-quality ice is produced 1-2 hours later.

USING THE ICE MAKER

Turn the switch at the lower end of the product to the "ICE" position. The product automatically starts ice production, which continues until the ice container has been filled with ice. Remove the ice using the supplied ice scoop found on the inside left wall of the ice maker. (If you place the ice scoop on the ice, it may be covered over by ice.)

The ice maker produces 24 pieces of ice every 30 minutes.

Important: Do not put anything other than ice in the ice container. Wine or beer bottles are unsanitary and a detached label may block the drain pipe.

The ice maker is not a freezer. It is a refrigerator with a freezer section. The ice in the container is slowly melting and replenished as needed.

ICE

The ice has a top hat shape (see Fig. 11-2). Newly produced ice is clear and transparent. The inside of the ice is sometimes cracked; however, such cracks commonly occur in the production process and disappear with time. Ice stored in the container for a long time may gather frost on the outside and look cloudy. This is normal and once water is poured on the ice, the frost disappears.

ICE CONTAINER

The product continues making ice until the level of ice reaches the temperature sensing tube (right side). It then ceases operation.

Models with a drain pump drain away melted ice when the ice maker is turned off. The pump works for only several seconds.

OPERATION TIME

It takes about 20-35 minutes to produce a set of 24 ice pieces. The length of one cycle of the ice maker (ice production and ice removal) differs depending upon the cleanness of the ice maker, the surrounding temperature, and the temperature of the water supplied to the ice maker. It takes about 10-12 hours to fill the empty ice container with ice.



Fig. 11-1 Switch

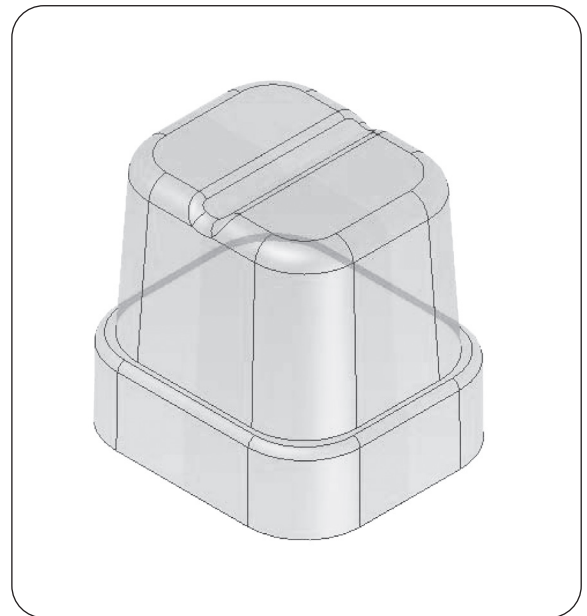

Fig. 11-2 Ice cube

ICE PRODUCTION

The ice production process largely consists of two cycles – ice production and ice removal. 24 pieces of ice are produced with each cycle of ice production and ice removal.

When water is sprayed on to the surface of the frozen ice-forming mold, the ice production cycle is started. When ice is removed and water is supplied to ice maker, the ice removal cycle is started.

ICE REMOVAL CYCLE

The compressor works during the progression of the ice removal cycle, but the pump motor and fan motor are stopped. The hot gas valve and water supply valve work. When the two valves are opened and the frozen surfaces are heated, ice drops down into the container. Then the ice removal cycle is stopped and the ice production cycle is started again by the program installed in the ice maker.

HOW IT MAKES ICE

The ice maker starts its work with the fixed quantity that has been fed into the water container. When water is sprayed on to the surface of the ice-forming mold, the water not containing mineral impurities freezes and attaches to the ice-forming mold. The water containing impurities drops down into the water container. During the progression of the ice production cycle, the mineral impurity level of the water in the water container rises.

During the progression of the ice removal cycle, water is fed to the ice maker, thereby diluting the water in the container, and washes a part of the concentrated minerals through the drain pipe.

ROUTINE MAINTENANCE AND CLEANING

All the exterior parts, door, ice container, condenser, circulatory parts for ice-production water, and ice scoop of the product should be kept clean.

The ice maker should be cleaned periodically. If the ice maker is kept clean, its lifespan will be extended. Regular cleaning should be performed at least once a year; twice a year is recommended, see the ICE-PRODUCTION SYSTEM section on following page. The frequency of cleaning the ice-production system should be increased depending upon the water quality.

CAUTION: Before service or cleaning is performed, ensure the switch is in the OFF position, the power supply is disconnected, and all components of the unit are completely cool.

EXTERIOR

The exterior of the appliance should be cleaned by first using stainless steel cleaner to remove grease and dirt. Always wipe with the grain (see Fig. 13-1). Next, apply stainless steel polish and wipe down using polish wipes to restore the stainless steel color.

If the gasket has spots/stains on its surface, remove and clean using soap and warm water. Use non-abrasive cloths or pads.

ICE CONTAINER

The ice container should be cleaned regularly. Mix 1 ounce of home bleaching agent and 2 gallons of warm water at 95°-115° (35-45° C) for use as the cleansing fluid. Moisten clean cloths with the cleansing fluid and scrub the inside of the ice container with the cloths. Pour a small quantity of the fluid into the drain pipe. See Fig. 13-2. **Thoroughly rinse with clean water and dry the interior.**

CONDENSER

The condenser should be cleaned 2-3 times a year to remove any lint that has penetrated the condenser. When cleaning the condenser, remove the front cover plate using a screwdriver. Then, remove any dust and lint from the condenser using a soft bristle brush and/or vacuum brush. See Fig. 13-3 and Fig. 13-4.

Important: To avoid possible bending of the condenser fins, clean the condenser in the direction of the fins (up and down).

CAUTION: If the condenser is not cleaned, the temperature may drop or the machine may experience technical problems or sustain damage.



Fig. 13-1 Wipe with grain

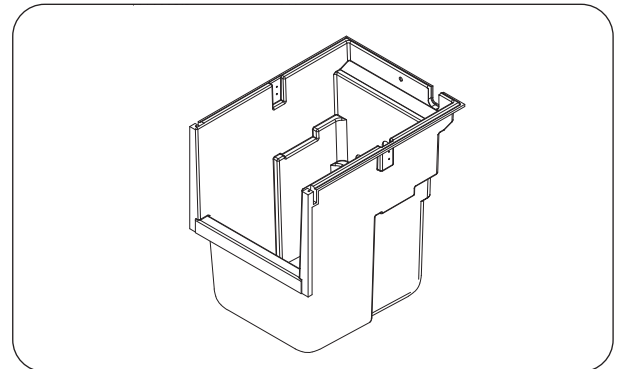

Fig. 13-2 Clean ice container

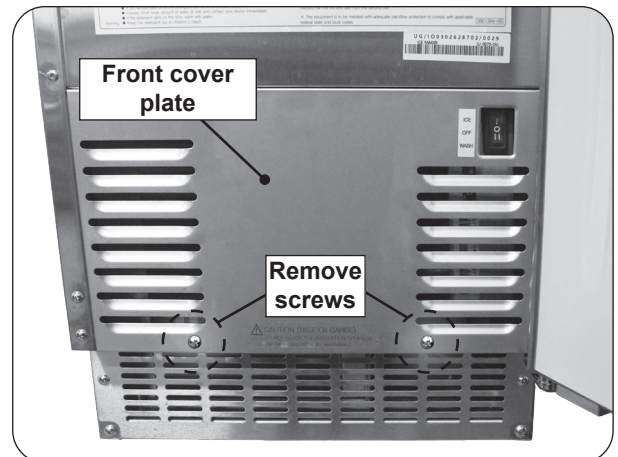

Fig. 13-3 Remove front cover plate

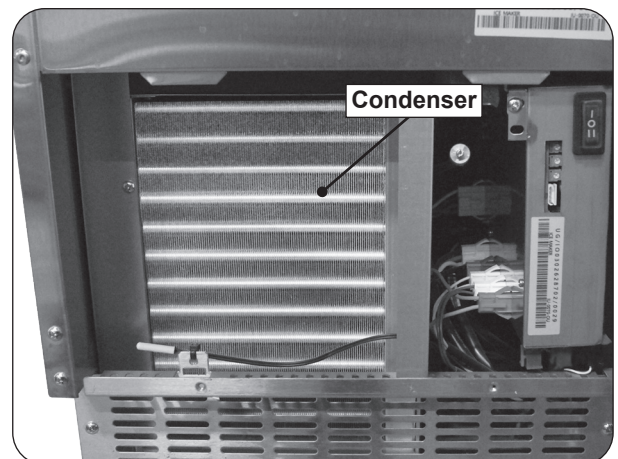

Fig. 13-4 Clean condenser

ROUTINE MAINTENANCE AND CLEANING (cont.)

ICE-PRODUCTION SYSTEM

1. Open the door and turn off the switch at the lower end of the front.
2. Re-connect the power supply.
3. Take out all the ice and dispose of it.
4. Pour 4 ounces of an ice machine cleaner (neutral detergent for dishwashing or equivalent) into the water container (6) of the ice maker.
5. Press the switch to the "WASH" position. The process by which water is supplied for 2 minutes and the circulation pump works for 4 minutes is repeated three times.
6. Repeat the above process 2-3 times. Add the cleaner to the water container if necessary, depending upon the washing process.
7. Clean the ice container (1), ice curtain (2), nozzle frame (3), spray nozzle (4), connective hose (5), the inside of the water container (6), slide grill (7), and ice scoop (8) using a mixture of washing agent and water. See Fig. 14-1.
8. **Thoroughly rinse all components with clean water and drain.**
9. Replace the removed ice. Regularly wash the ice scoop. It may be washed together with other food containers.

This procedure is for purposes of cleaning the ice-production system only. To treat the ice-production system for scaling, follow the same procedure above using equal parts vinegar and water instead of detergent.

WARNING: When using detergents and cleaning agents, **the safety precautions and instructions labeled on those products must be observed.**

Important: Disconnect the power supply if other services will be performed to the appliance.

LONG TERM STORAGE OR NON-OPERATION (WINTERIZING)

1. **Clean the ice-production system** (see previous section).
2. Disconnect the power supply.
3. Empty the water container. Remove the back panel from the ice maker. Remove the pump hose.
4. Disconnect the inlet hose from the water supply shut-off valve.
5. Remove the plug from underneath the water container (see Fig. 14-2).
6. Reconnect the power and turn the switch to the "WASH" position to open the water supply valve and to remove the water from the inlet pipe inside the ice maker.
7. Turn off the ice maker and disconnect the power supply.
8. Re-insert the reservoir plug once water is completely removed and the unit is completely dry.
9. Leave the door open to allow for circulation and to prevent mold and mildew.
10. Leave water supply line and power supply disconnected until ready to reuse.

When using the ice maker in the future, re-install all components removed during this procedure. Repeat the steps in the INITIAL OPERATION section.

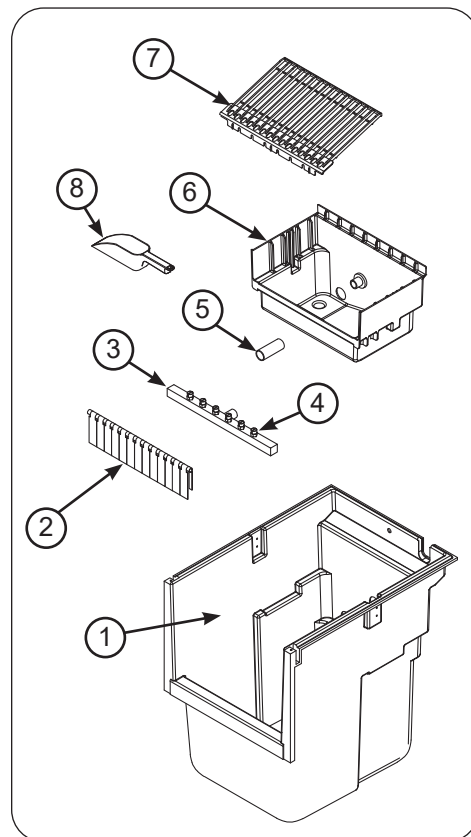

Fig. 14-1 Ice-production system components

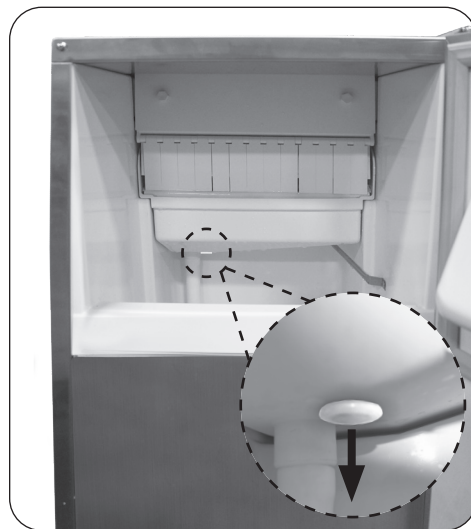

Fig. 14-2 Remove plug

TROUBLESHOOTING

| PROBLEM | POSSIBLE CAUSE | CORRECTION |
|--|--|--|
| Ice maker does not operate | <ol style="list-style-type: none"> 1. Ice maker is unplugged 2. Breaker tripped 3. Switch turned to "OFF" 4. Storage bin full, keeping ice maker off 5. Drain pipe blocked (drain pump model) 6. Drain pump malfunction (drain pump model) | <ol style="list-style-type: none"> 1. Plug the ice maker in. 2. Reset breaker - if it happens again, call an authorized service center. 3. Turn switch to "ICE". 4a. Ice on sensor tube – it is normal for ice maker to be off. 4b. Ice maker in location below 50° (10° C) – location must be warmer for ice maker to operate. 5. Clean the interior of drain pipe. 6a. Check the drain pump. 6b. Contact dealer. |
| Ice cubes are too small | <ol style="list-style-type: none"> 1. Not enough water | <ol style="list-style-type: none"> 1a. Check water supply – filter may be restricted. 1b. Check inlet water valve – inlet screen may be restricted. |
| Ice cubes are partially formed – ragged sides | <ol style="list-style-type: none"> 1. Spray jets partially clogged | <ol style="list-style-type: none"> 1. Clean ice making system. |
| Ice maker makes ice, but storage bin does not fill with ice | <ol style="list-style-type: none"> 1. Storage bin should fill with ice and ice maker shut off in 12~16 hours – if not, condenser may be dirty 2. Storage bin drain may be partially restricted 3. Air flow to ice maker may be obstructed | <ol style="list-style-type: none"> 1. Clean condenser. 2. Clean out drain, check installation. 3. Check installation – kick plate/grill must be free of obstructions. |
| Ice cubes are partially formed – white at the bottom | <ol style="list-style-type: none"> 1. Not enough water in reservoir | <ol style="list-style-type: none"> 1a. Check water supply – filter may be restricted. 1b. Check inlet water valve – inlet screen may be restricted. 1c. Check for water leak in reservoir. |
| Unit operates but no ice falling in storage bin | <ol style="list-style-type: none"> 1. Ice may be stuck in the evaporator and the unit is "frozen up" 2. Too much heat load 3. No water spray 4. No airflow 5. Compressor does not operate properly or at all 6. Not enough refrigerant 7. Hot gas valve leaks through | <ol style="list-style-type: none"> 1a. Check water supply – filter may be restricted. 1b. Check inlet water valve – inlet screen may be restricted or valve does not operate. 1c. Hot gas valve may not operate – check and repair or replace. 2. Inlet water valve leaks through, must be replaced. 3. Water pump does not operate, must be replaced or check for water leak in reservoir. 4a. Fan motor does not operate or fan blade is broken, must be replaced. 4b. Condenser completely blocked, must be cleaned. 5. Contact dealer. 6. Contact dealer. 7. Contact dealer. |

WARRANTY

ONE-YEAR WARRANTY - Fire Magic® electric accessories are warranted for one year from the date of purchase.

A COPY OF YOUR SALES SLIP FOR PROOF OF PURCHASE IS REQUIRED

This warranty applies to the original purchaser for products which are installed in the United States or Canada and which are operated and maintained as intended for single family residential usage. This warranty is valid only with proof of purchase, commences on the date of purchase, and terminates (both as to original and any replacement products) on the anniversary date of the original purchase of the product per the above schedules.

This warranty covers defects in material and workmanship. This warranty **does not** cover parts which become defective as a result of negligence, misuse, use not in compliance with the Installation and Owner's Manual, accidental damage, improper handling, improper storage, improper installation, **lack of required routine maintenance** (as specified in the Installation and Owner's Manual), or electrical damage. Product must be installed as specified in the Installation and Owner's Manual by a **qualified professional installer**. This warranty **does not** apply to rust, corrosion, oxidation, or discoloration unless the affected part becomes inoperable. RHP products including valves, pilots and controls, are designed and certified to be used as a system. Modifications to products which are not specifically authorized will void this warranty and could render the product to be unsafe. Burners, valves, parts, accessories, remotes, etc. used with this product must be RHP products or this warranty is void.

Warranted items will be repaired or replaced at RHP's sole discretion. This warranty **does not** cover labor or labor related charges, except as provided by separate specific written programs from RHP. All repair work must be performed by a qualified professional service person and requires prior approval of RHP.

RHP may require the defective product or part to be returned to the factory to determine the cause of failure. RHP will pay freight charges if the product or part is determined to be defective. This warranty does not cover breakage in shipment from our independent distributor to its customer if the damage is determined to have occurred during that shipment.

This warranty specifically excludes liability for **indirect, incidental**, or consequential damages. Some states and provinces do not allow the exclusion or limitation of incidental or consequential damages, so the above exclusion may not apply to you. This warranty gives you specified legal rights, and you may have other rights that vary from state to state or province.

For additional information regarding this warranty, or to place a warranty claim, contact the RHP dealer where the product was purchased.

When contacting your RHP dealer or the R.H. Peterson Co., please provide the following information:

- Your name, address, telephone number, e-mail
- Sales receipt showing where purchased and date purchased
- Model number, serial number of product, date code
- Relevant information: installer, additions, repairs, when defect was first noted

**TO REGISTER YOUR PRODUCT ONLINE GO TO: WWW.RHPETERSON.COM,
AND CLICK ON PRODUCT REGISTRATION. THANK YOU FOR YOUR PURCHASE.**